

8. 制动及用气系统-Air and Brake System

序号/ No.	名 称 / Designation	页 码 /Page No.
8,01	发动机排气制动及操纵装置/Engine Brake System	1
8,02	取力器电控气操纵装置（非富勒变速器）/PTO Control System	2
8,03	辅助用气分配模块/Air distributor block	3
8,04	辅助用气分配模块（无堵）/Air distributor block	4
8,05	双桥轴间差速锁气操纵装置/Interaxle Diff. Control System 1	5
8,06	空气座椅气操纵装置/Seat Air System	6
8,07	双音气喇叭操纵装置（金属保险杠）/Horn Air System	7
8,08	双桥轮间差速锁气操纵装置/Interwheel Diff. Control System 2	8
8,09	辅助用气储气筒装置/Air Supply Device	9
8,10	驾驶室气囊悬置供气装置（两气囊）/Air Supply Device	11
8,11	变速器气操纵装置/Gearbox Air System 2	12
8,12	差速锁工作缸/Cylinder Air	13
8,13	制动气室（中后桥）/Brake Actuator	14
8,14	制动系统供气装置/Air Supply Device	15
8,15	驾驶室制动装置/Brake Device In Cab	17
8,16	单前轴制动装置/Front Axle Brake Device	18
8,17	双桥制动装置/Double Drive Axle Brake Device	19
8,18	HOWO组合踏板操纵装置（新开关/共轨）/Pedal Control Device	21

8,19	HW6X4底盘制动装置（09版长轴距）/Chassis Brake Device		25
8,20	前轴半挂牵引车制动装置/Front Axle Brake Device 2		31

8.01 发动机排气制动及操纵装置/Engine Brake System

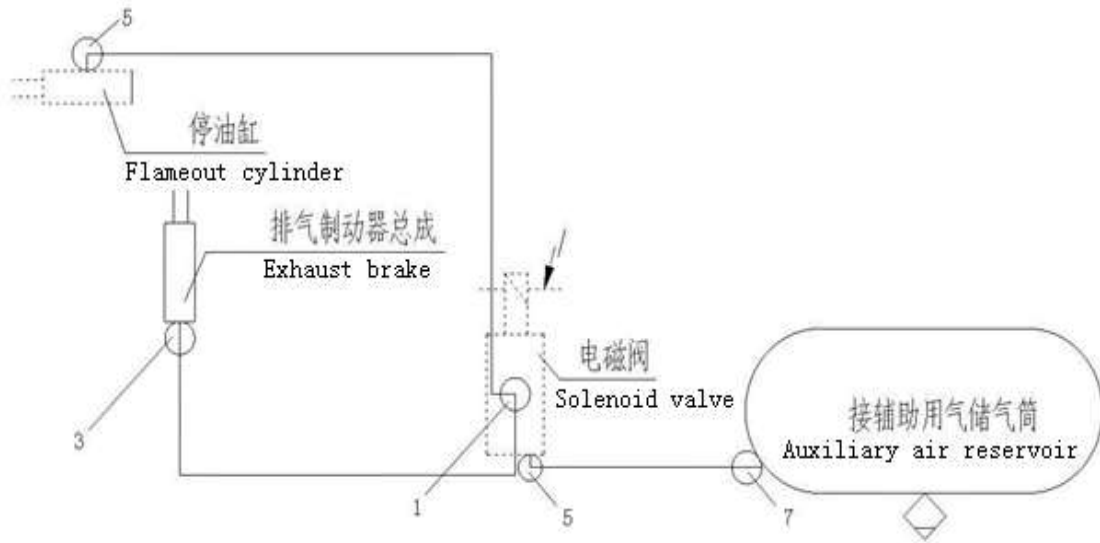

8.01 发动机排气制动及操纵装置/Engine Brake System

序号 No.	零部件图号 Part No.	名称	Part Name	数量 Qty	备注 Remark
1	WG9000361308	L型三通接头体NG6/NW4	"L" connector NG6/NW4	2	
3	WG9000361107	直通接头体NG6/NW4	Connector NG6/NW4	2	
5	WG9000361207	直角接头体NG6/NW4	Connector NG6/NW4	1	
7	WG9000361103	直通接头体NG12/NW4	Connector NG12/NW4	1	
9	WG9000361001	弹性元件NG6	Connector NG6	3	
11	WG9000361002	卡簧NG6	Snap spring NG6	3	
13	WG9000361003	螺母座NG6	Nut seat NG6	3	
15	190003179782	聚酰胺管 (Φ6*1)	Plastic pipe (Φ6*1)	4m	
16	1880 360083	支承板	Plate	1	
17	Q150B1035	六角头螺栓	Screw	1	
18	Q40110	平垫圈	Washer	1	
19	Q40310	弹簧垫圈	Spring washer	1	
20	Q340B10	六角螺母	Nut	1	
21	WG9100360134	隔环	Spacer	1	
22	199100360134	隔环	Spacer	1	
23	190003171390	塑料紧固带	Fastener	1	

8.05 双桥轴间差速锁气操纵装置/Interaxle Diff. Control System 1

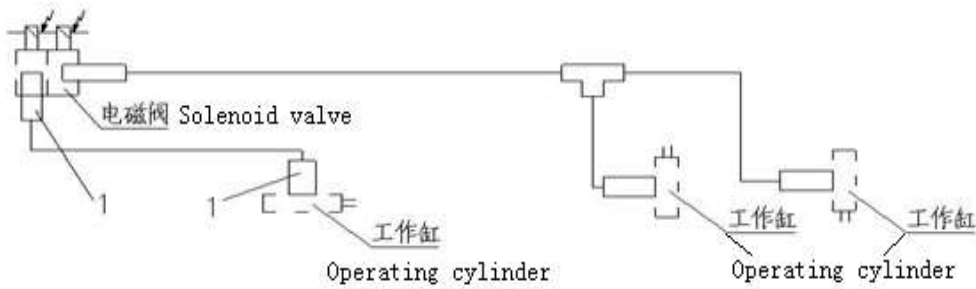

8.05 双桥轴间差速锁气操纵装置/Interaxle Diff. Control System 1

序号 No.	零部件图号 Part No.	名称	Part Name	数量 Qty	备注 Remark
1	WG9000361107	直通过接头体NG6/NW4	Connector NG6/NW4	2	
2	WG9000361010	堵塞M10X1	Plug M10X1	1	
3	WG9000361001	弹性元件NG6	Connector NG6	2	
4	WG9000361002	卡簧NG6	Snap spring NG6	2	
5	WG9000361003	螺母座NG6	Nut seat NG6	2	
6	190003179782	聚酰胺管 (Φ6*1)	Plastic pipe	5m	

10	WG9000361107	直通接头体NG6/NW4	Connector NG6/NW4	3	
12	WG9000361001	弹性元件NG6	Connector NG6	2	
14	WG9000361002	卡簧NG6	Snap spring NG6	2	
16	WG9000361003	螺母座NG6	Nut seat NG6	2	
18	190003179782	聚酰胺管 (Φ6*1)	Plastic pipe (Φ6*1)	8m	
19	WG9718710003	气喇叭电磁阀	Solenoid valve	1	
21	Q150B0816	六角头螺栓	Screw	1	
22	Q41208	外锯齿锁紧垫圈	Washer	1	
25	WG9725270017	双音气喇叭支架	Bracket	1	
27	Q150B0625	六角头螺栓	Screw	2	

8.08 双桥轮间差速锁气操纵装置/Interwheel Diff. Control System 2

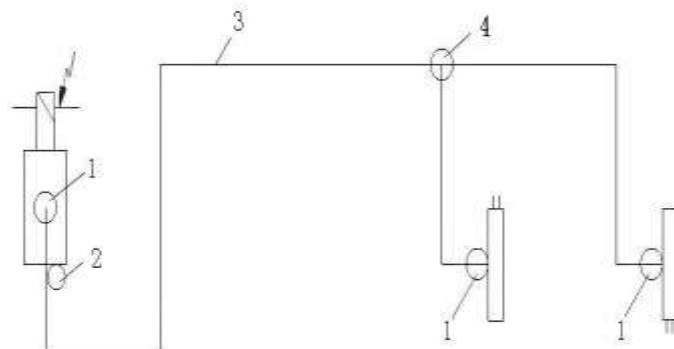

8.08 双桥轮间差速锁气操纵装置/Interwheel Diff. Control System 2

序号 No.	零部件图号 Part No.	名称	Part Name	数量 Qty	备注 Remark
1	WG9000361107	直通接头体NG6/NW4	Connector NG6/NW4	3	
2	WG9000361010	堵塞M10X1	Plug M10X1	1	
3	190003179782	聚酰胺管 (Φ6*1)	Plastic pipe (Φ6*1)	10m	
4	WG9000361316	T型三通接头体3-NW4	"T" Connector 3-NW4	1	

3	Q150B1030	六角头螺栓	Screw	4	
4	Q40110	平垫圈	Washer	4	
5	Q40310	弹簧垫圈	Spring washer	4	
6	WG9000361402	放水阀	Draining valve	1	
7	WG9719360024	紧固带总成	Tension strap	2	
8	Q218B0880	内六角圆柱头螺钉	Screw	2	
9	WG700 550013	张紧销	Tension bolt	2	
10	WG9000360519	溢流阀0.6MPa无回流	Over-flow valve	1	
11	WG09 190017	拉紧销	Tension bolt	2	
12	WG9000361201	直角接头体NG8/NW6	Connector NG8/NW6	1	
13	WG9000361204	直角接头体NG12/NW9	Connector NG12/NW9	3	
14	WG9000361406	T型接头体NW9/NG12/TEST	"T" Connector NW9/NG12/	1	
15	190003559385	隔壁直通接头体2-M22×1	Connector 2-M22×1.5	1	
16	WG9000361004	弹性元件NG8	Connector NG8	1	
17	WG9000361005	卡簧NG8	Snap spring NG8	1	
18	WG9000361006	螺母座NG8	Nut seat NG8	1	
19	WG9000361007	弹性元件NG12	Connector NG12	5	
20	WG9000361008	卡簧NG12	Snap spring NG12	5	

8.09 辅助用气储气筒装置/Air Supply Device

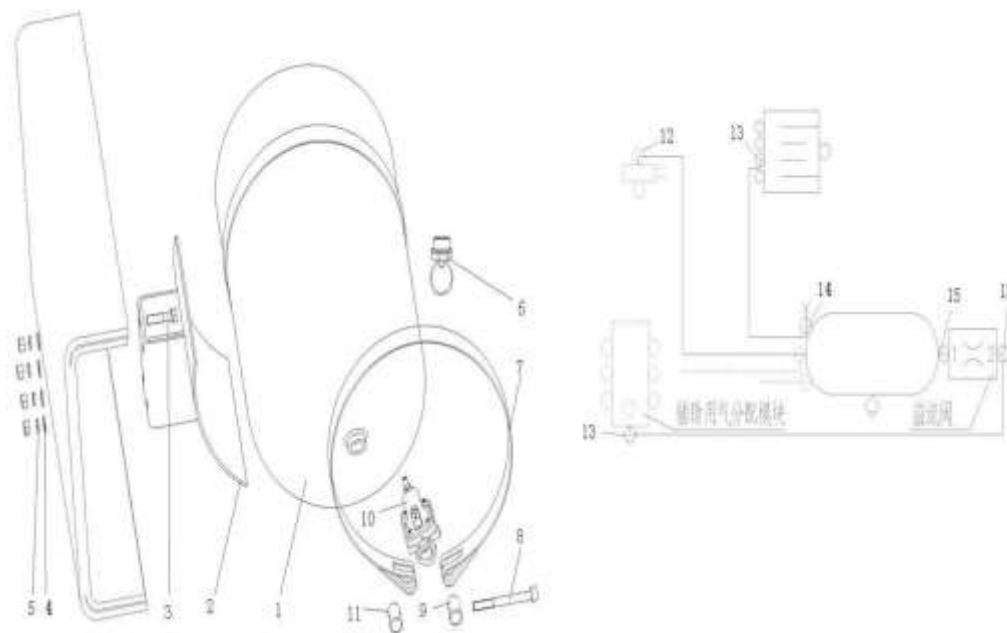

8.09 辅助用气储气筒装置/Air Supply Device

序号	零部件图号	名称	Part Name	数量	备注
No.	Part No.			Qty	Remark

六缸空压机
Dual cylinder compressor

8.14 制动系统供气装置/Air Supply Device

序号 No.	零部件图号 Part No.	名称	Part Name	数量 Qty	备注 Remark
1	AZ9718360204	管子15 空压机/软管	Hose	1	
2	WG9112360189	直通接头体 (M26/M22)	Connector (M26/M22)	1	
3	WG9719360025	橡胶软管 (长670mm)	Hose (长670mm)	1	
4	WG9100360183	不锈钢波纹管总成(300mm)	Tube ass.	1	
5	190003989340	软管卡箍	Hose clip	2	
6	190003559562	卡套	Cutting sleeve	2	
7	Q150B0620	六角头螺栓	Screw	4	
8	Q40306	弹簧垫圈	Spring washer	4	
9	Q340B06	I型六角螺母	Nut	4	
10	Q40108	平垫圈	Washer	3	
11	Q40308	弹簧垫圈	Spring washer	3	
12	Q340B08	I型六角螺母	Nut	1	
13	AZ9718360010	角形支架	Angle bracket	1	
14	Q340B08	I型六角螺母	Nut	2	
15	Q150B0635	六角头螺栓	Screw	1	
16	1185 770036	紧固夹子	Clip	1	
17	Q40108	平垫圈	Washer	2	
18	AZ9719360006	支架	Bracket	1	
19	1381F 140090	护套	Protecting bush	1	
20	Q150B0620	六角头螺栓	Screw	1	

8.14 制动系统供气装置/Air Supply Device

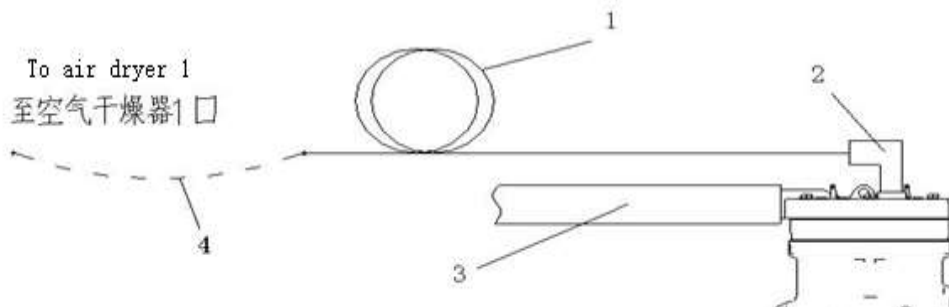

双缸空压机

Dual cylinder compressor



8.14 制动系统供气装置/Air Supply Device

序号 No.	零部件图号 Part No.	名称	Part Name	数量 Qty	备注 Remark
21	Q40308	弹簧垫圈	Spring washer	2	
22	190003989340	软管卡箍	Hose clip	2	
23	190003559562	卡套	Cutting sleeve	2	
24	Q40106	平垫圈	Washer	2	
25	Q150B0845	六角头螺栓	Screw	1	
26	Q40306	弹簧垫圈	Spring washer	2	
27	WG80 360199	夹子	Clip	2	
28	Q150B0830	六角头螺栓	Screw	1	
29	AZ9719360007	支架	Bracket	1	
30	Q340B06	I型六角螺母	Nut	2	
31	190003559515	管接头用螺母	Nut	2	
32	190003098031	密封垫圈	Washer	1	
33	WG9125360209	螺旋管固定支架	Bracket	1	
34	WG9000365401	单管夹(φ15)	Clip(φ15)	4	
35	Q40206	大垫圈	Washer	4	
36	WG9718360010	角形支架	Angle bracket	1	
37	Q150B0845	六角头螺栓	Screw	1	
38	199012360441	角形支架	Angle bracket	2	
39	Q150B0830	六角头螺栓	Screw	2	
41	WG9000365404	双管夹(φ15)	Clip(φ15)	1	

8.15 驾驶室制动装置/Brake Device In Cab

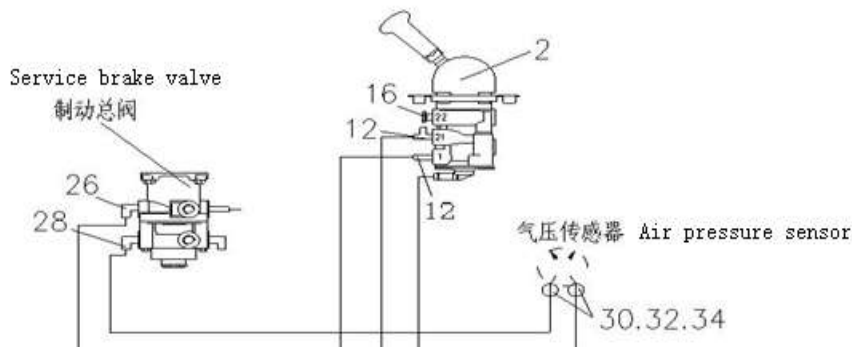

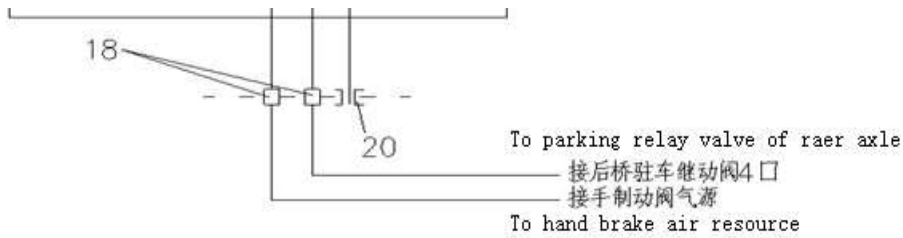

8.15 驾驶室制动装置/Brake Device In Cab

序号 No.	零部件图号 Part No.	名称	Part Name	数量 Qty	备注 Remark
2	WG9000360522	手制动阀	Parking brake valve	1	
4	Q150B0616	六角头螺栓	Screw	2	
5	Q40306	弹簧垫圈	Spring washer	2	
6	WG9000361004	弹性元件NG8	Connector NG8	2	
8	WG9000361005	卡簧NG8	Clip NG8	2	
10	WG9000361006	螺母座NG8	Nut seat NG8	2	
12	WG9000361307	L型三通接头体NG8	"L" connector NG8	2	
16	WG9000361011	堵塞NG8-M16×1.5	Plug NG8-M16×1.5	1	
18	WG9000361403	组合踏板支架过板接头	Connector	2	
20	WG9719360018	橡胶护套	Sleeve	1	
22	WG9719360019	堵塞	Plug	5	
24	WG9725360036	方型堵塞	Plug	1	
26	WG9000361207	直角接头体NG6/NW4	Connector NG6/NW4	1	
28	WG9000361107	直通接头体NG6/NW4	Connector NG6/NW4	3	
30	WG9000361108	直通隔壁接头体NG6	Connector NG6	2	
32	WG9000361013	六角薄螺母M16X1.5	Nut M16X1.5	2	
34	WG9000361032	O型圈13X2	O-ring 13X2	2	
38	190003179782	聚酰胺管(Φ6*1)	Plastic pipe (Φ6*1)	2m	
39	190003179781	聚酰胺管(Φ8*1)	Plastic pipe (Φ8*1)	3m	
40	190003171390	塑料紧固带B5*180	Fastener B5*180	5	

8.16 单前轴制动装置/Front Axle Brake Device

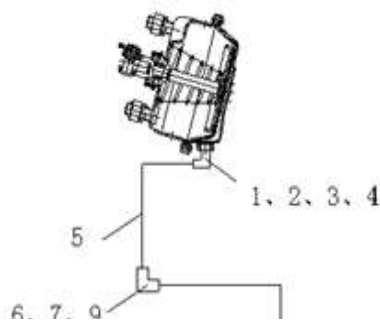

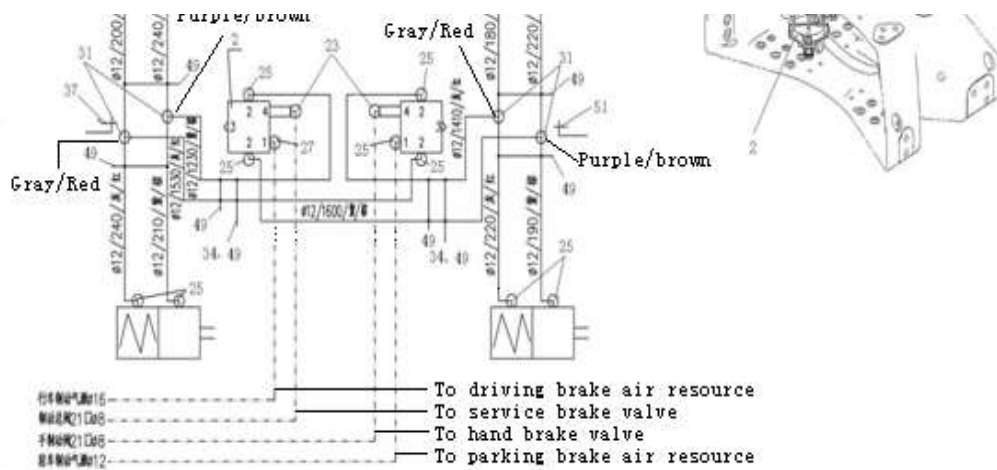

8.17 双桥制动装置/Double Drive Axle Brake Device

序号 No.	零部件图号 Part No.	名称	Part Name	数量 Qty	备注 Remark
2	WG9000360524	继动阀	Relay valve	2	
5	Q150B1035	六角头螺栓	Screw	4	
6	Q40110	平垫圈	Washer	4	
7	Q40310	弹簧垫圈	Spring washer	4	
8	Q340B10	六角螺母	Nut	4	
9	Q40308	弹簧垫圈	Spring washer	4	
10	Q340B08	1型六角螺母	Nut	4	
11	WG9000361004	弹性元件NG8	Connector	2	
13	WG9000361005	卡簧NG8	Snap ring	2	
15	WG9000361006	螺母座NG8	Nut seat	2	
17	WG9000361007	弹性元件NG12	Connector	14	
19	WG9000361008	卡簧NG12	Snap ring	14	
21	WG9000361009	螺母座NG12	Nut seat	14	
23	WG9000361201	直角接头体NG8/NW6	Connector	2	
25	WG9000361204	直角接头体NG12/NW9	Connector	11	
27	WG9000361203	直角接头体NG12/NW12	Connector	1	
29	WG9000361406	T型接头体NW9/NG12/TEST	"T" Connector	2	
31	WG9000361310	T型三通接头体3-NW9	"T" Connector	4	
33	190003179785	聚酰胺管 (Φ12*1.5)	Plastic pipe	9m	
34	WG9725360088	塑料紧固带总成	Fastener	4	

8.17 双桥制动装置/Double Drive Axle Brake Device



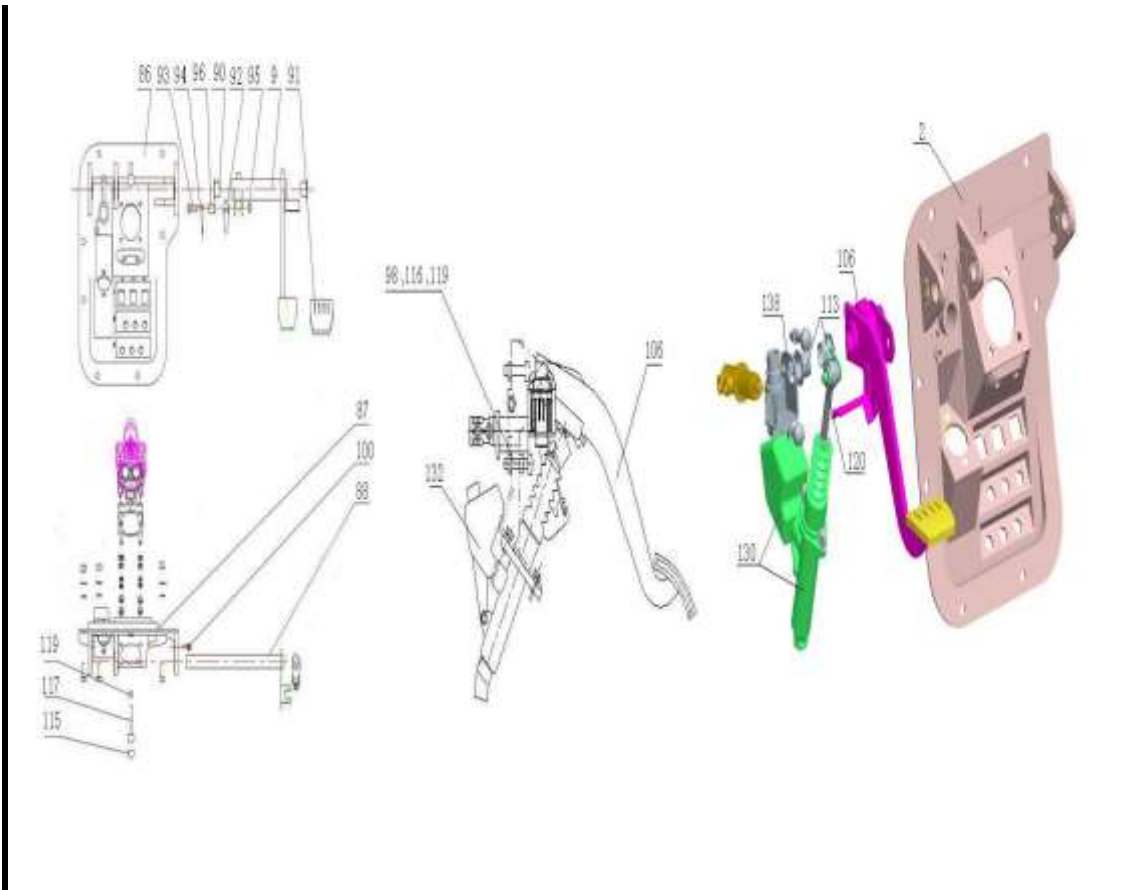

8.18 HOWO组合踏板操纵装置(新开关/共轨)/Pedal Control Device

序号 No.	零部件图号 Part No.	名称	Part Name	数量 Qty	备注 Remark
92	AZ9719360063	挺杆	Rod	1	
93	Q173B0845	六角头螺杆带孔螺栓	Bolt	1	
94	Q5002016	开口销	Pin	1	
95	Q341B08	I型六角螺母-细牙	Nut	1	
96	AZ9719360062	销轴	Pin	1	
97	Q150B0845	六角头螺栓	Bolt	1	
98	AZ9123360067	堵头 (2819602003691)	Plug	1	
99	Q340B08	1型六角螺母	Nut	1	
100	Q1840616	六角法兰面螺栓	Bolt	1	
101	WG9000360520	制动总阀	Service brake valve	1	
102	Q33208	2型全金属六角锁紧螺母	Nut	4	
103	Q40308	弹簧垫圈	Spring washer	4	
104	AZ9725230010	离合器操纵部分(共轨)	Clutch control section (com	1	
106	AZ9719230225	离合器踏板总成	Clutch pedal assembly	1	
107	AZ9123360113	踏板 (2814822520941)	Clutch foot pedal	1	
108	AZ9719230005	离合器踏板轴轴套	Sleeve	1	
109	AZ9719230022	限位角板	Bracket	1	
110	AZ9719230044	离合器踏板臂	Clutch pedal arm	1	
111	AZ9719230053	支架	Bracket	1	

112	AZ9719230224	支架	Bracket	1	
-----	--------------	----	---------	---	--

8.18 HOWO组合踏板操纵装置(新开关/共轨)/Pedal Control Device

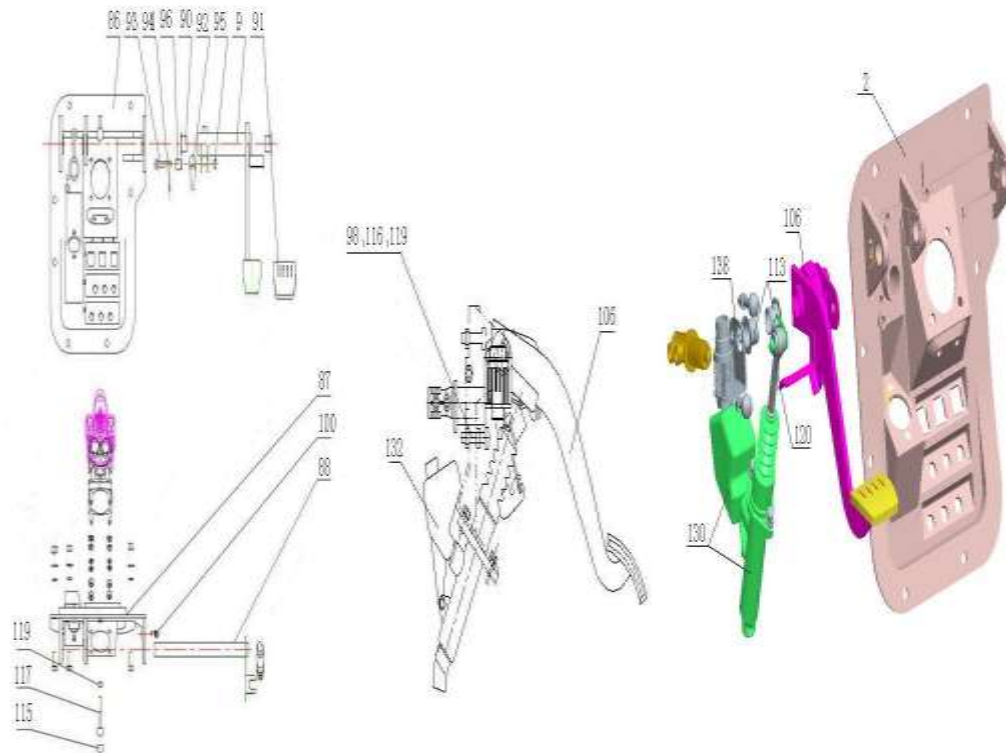

8.18 HOWO组合踏板操纵装置(新开关/共轨)/Pedal Control Device

序号	零部件图号	名称	Part Name	数量	备注
No.	Part No.			Qty	Remark
113	AZ9719360060	自润滑衬套	Bushing	2	
114	AZ9123230226	踏板橡胶罩	Rubber cover	1	
115	AZ9123360067	堵头 (2819602003691)	Plug	2	
116	Q150B0830	六角头螺栓	Bolt	1	
117	Q150B0845	六角头螺栓	Bolt	1	
118	Q40308	弹簧垫圈	Spring washer	2	
119	Q340B08	I型六角螺母	Nut	2	
120	AZ9719230228	销轴总成	Pin shaft ass.	1	
121	AZ9719230226	销轴	Pin	1	
122	AZ9719230227	支架	Bracket	1	
123	Q150B0616	六角头螺栓	Bolt	1	
124	Q40106	平垫圈	Washer	1	
125	Q40306	弹簧垫圈	Spring washer	1	
126	Q340B06	I型六角螺母	Nut	1	
127	AZ9719230222	离合器总泵推杆	Rod ass.	1	
128	AZ9123230053	无内圈滚针轴承	Needle bearing	1	
129	AZ9719230229	垫圈	Washer	2	

130	WG9719230023	离合器总泵及储油罐总成	Clutch master cylinder and	1	
133	AZ9719230231	弹簧座	Base	1	
134	Q150B0820	六角头螺栓	Bolt	2	

8.18 HOWO组合踏板操纵装置(新开关/共轨)/Pedal Control Device

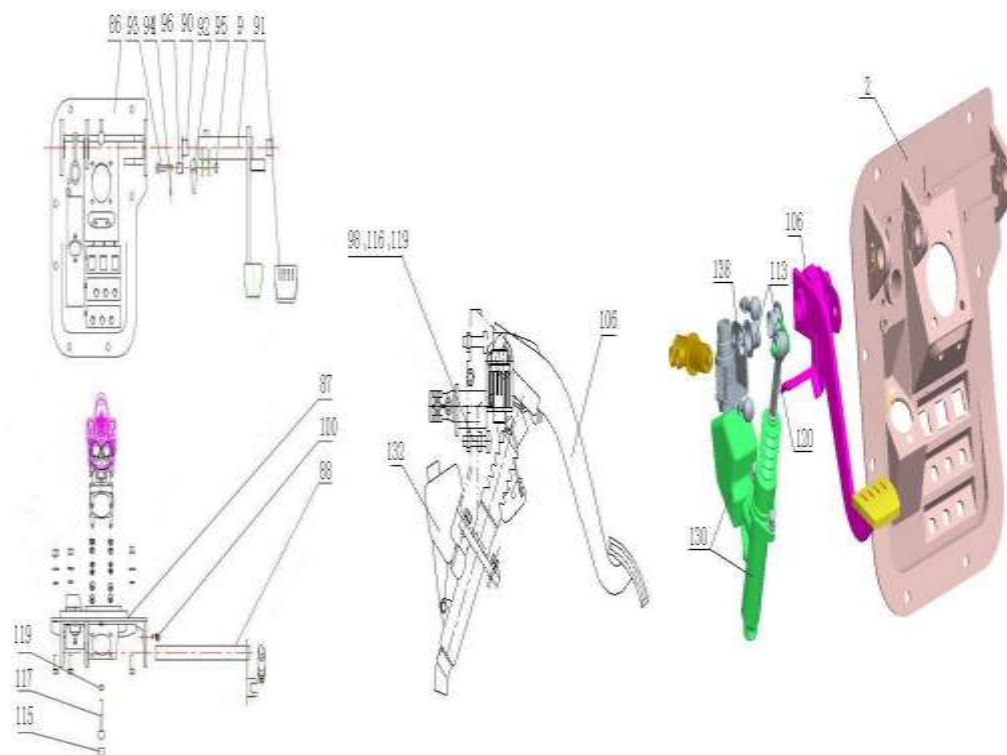

8.18 HOWO组合踏板操纵装置(新开关/共轨)/Pedal Control Device

序号 No.	零部件图号 Part No.	名称	Part Name	数量 Qty	备注 Remark
135	Q40108	平垫圈	Washer	2	
136	Q40308	弹簧垫圈	Spring washer	2	
137	AZ9719230232	回位弹簧	Spring	1	
138	AZ9719230058	信号开关支架	Bracket	1	
139	Q150B0620	六角头螺栓	Bolt	1	
140	Q40306	弹簧垫圈	Spring washer	1	
141	Q40106	平垫圈	Washer	1	
142	WG9718710005	离合器开关	Clutch switch	1	
143	AZ9719230021	密封堵(内饰件厂)	Plug	1	
144	WG9725716002	双触点制动灯开关	Switch	1	

8.19 HW6X4底盘制动装置（09版长轴距）/Chassis Brake Device

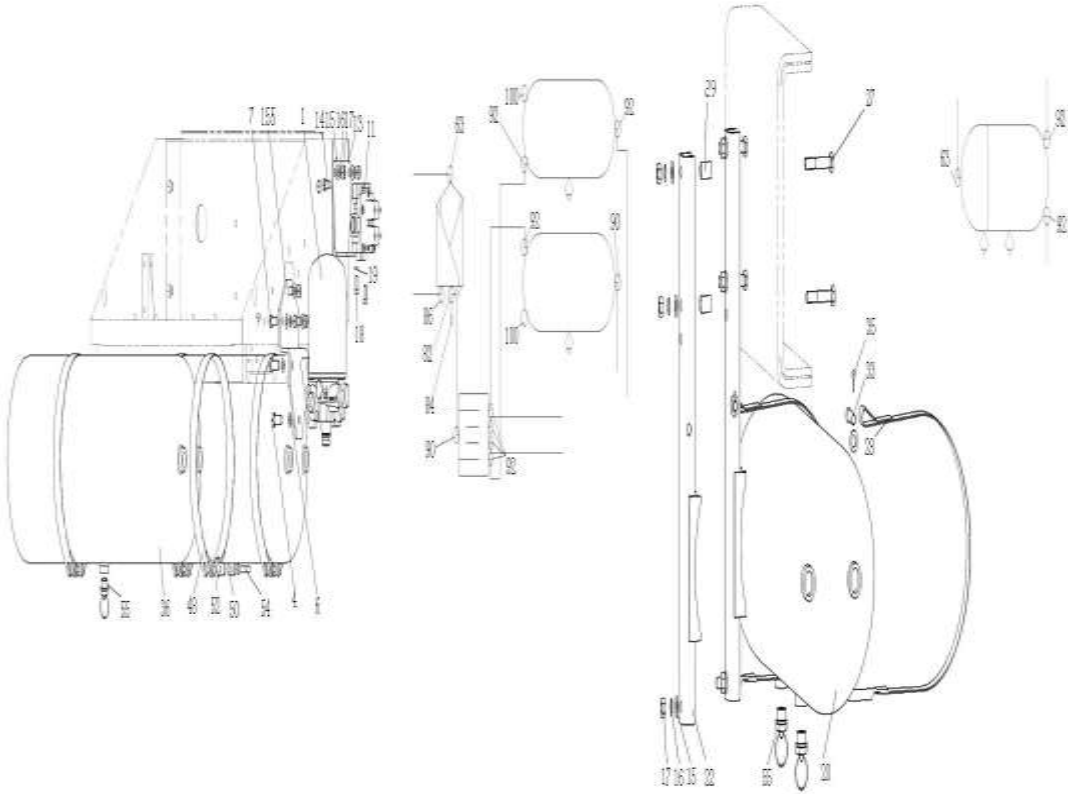

8.19 HW6X4底盘制动装置（09版长轴距）/Chassis Brake Device

序号	零部件图号	名称	Part Name	数量	备注
No.	Part No.			Qty	Remark
1	WG9000360521	空气干燥器	Air dryer	1	
4	Q151C1230	六角头螺栓(细牙)	Screw	3	
5	Q40112	平垫圈	Washer	3	
6	Q40312	弹簧垫圈	Spring washer	3	
7	Q150B1025	六角头螺栓	Screw	3	
8	Q40110	平垫圈	Washer	3	
9	Q40310	弹簧垫圈	Spring washer	3	
10	Q340B10	六角螺母	Nut	3	
11	WG9000360523	四回路保护阀	4-circuit protecting valve	1	
13	AZ9719360013	四回路保护阀支架	Bracket	1	
14	Q150B1020	六角头螺栓	Screw	2	
15	Q40110	平垫圈	Washer	2	
16	Q40310	弹簧垫圈	Spring washer	2	

17	Q340B10	六角螺母	Nut	2	
18	Q150B0818	六角头螺栓	Screw	2	
19	Q40308	弹簧垫圈	Spring washer	2	
20	WG9000360712	储气筒总成双腔Φ246/20	Air reservoir (25L)	1	
25	WG93 250096	隔套	Spacer	4	
27	Q150B1065	六角头螺栓	Screw	4	
28	WG9731360005	紧固带总成	Tension strap	2	

8.19 HW6X4底盘制动装置 (09版长轴距) /Chassis Brake Device

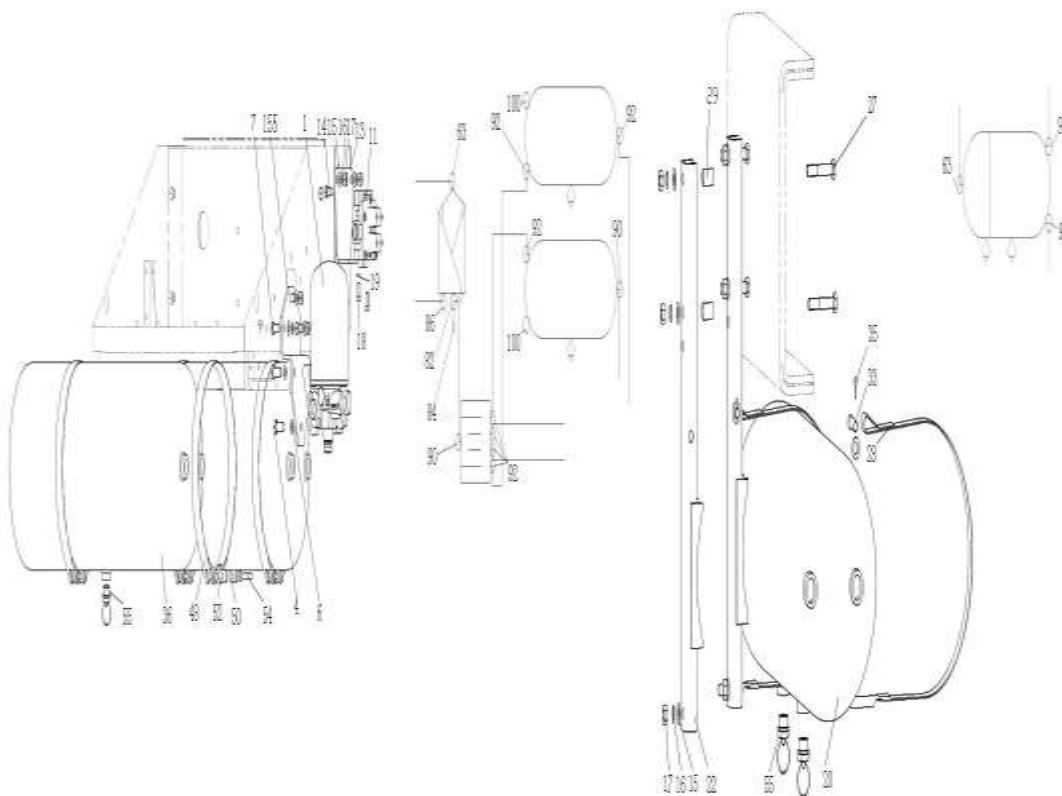

8.19 HW6X4底盘制动装置 (09版长轴距) /Chassis Brake Device

序号	零部件图号	名称	Part Name	数量	备注
No.	Part No.			Qty	Remark
30	Q40110	平垫圈	Washer	6	
31	Q40310	弹簧垫圈	Spring washer	6	
32	Q340B10	六角螺母	Nut	6	
33	Q5101048	销轴	Shaft	2	
34	Q40110	平垫圈	Washer	2	
35	Q5003214	开口销	Split pin 1	2	
36	WG9000360701	储气筒总成Φ246/30L	Air reservoir	2	
38	WG9000360700	储气筒总成Φ246/20L	Air reservoir	1	
44	Q150B0835	六角头螺栓	Screw	4	
45	Q40108	平垫圈	Washer	4	
46	Q40308	弹簧垫圈	Spring washer	4	

47	Q340B08	1型六角螺母	Nut	4	
48	WG99112270012	紧固带总成	Tension strap	6	
50	WG09 190017	拉紧销	Tension bolt	6	
52	WG700 550013	张紧销	Tension bolt	6	
54	Q218B0880	内六角圆柱头螺钉	Screw	6	
55	WG9000361402	放水阀	Draining valve	5	
57	190003179781	聚酰胺管 (Φ8*1)	Plastic pipe	22m	
58	190003179785	聚酰胺管 (Φ12*1.5)	Plastic pipe	30m	
60	AZ9725360102	管子15软管/干燥器1	Tube	1	

8.19 HW6X4底盘制动装置 (09版长轴距) /Chassis Brake Device

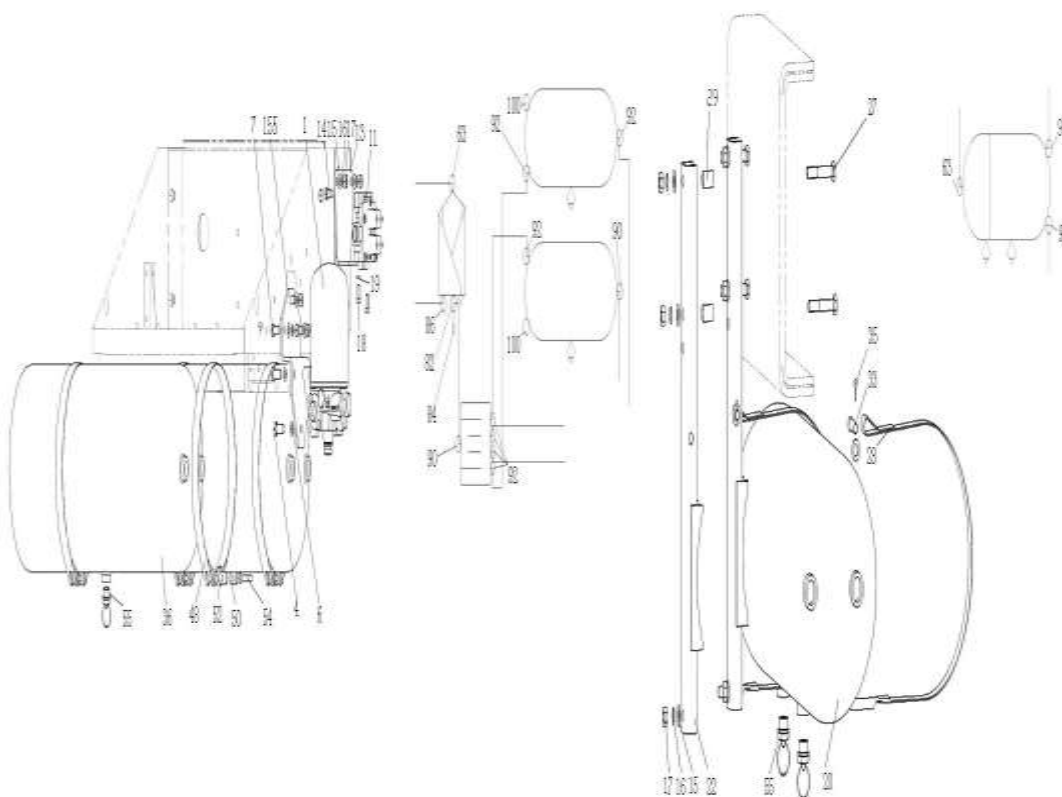

8.19 HW6X4底盘制动装置 (09版长轴距) /Chassis Brake Device

序号	零部件图号	名称	Part Name	数量	备注
No.	Part No.			Qty	Remark
61	190003559515	管接头用螺母	Nut	2	
62	190003559562	卡套	Cutting sleeve	2	
63	AZ9100362002	卡套式直角接头体	Connector	1	
64	WG9000361015	六角薄螺母M22X1.5	Nut	1	
66	WG9000361016	支撑垫圈M22X1.5	Ring	1	
68	WG9000361017	O型圈20.3X2.4	O-ring	1	
70	WG9000361004	弹性元件NG8	Connector NG8	1	
72	WG9000361005	卡簧NG8	Snap spring NG8	1	
74	WG9000361006	螺母座NG8	Nut seat NG8	1	

76	WG9000361007	弹性元件NG12	Connector NG8	15	
78	WG9000361008	卡簧NG12	Snap spring NG8	15	
80	WG9000361009	螺母座NG12	Nut seat NG8	15	
82	WG9000361301	L型三通接头体NG12/NW12	"L" Connector	1	
84	WG9000361401	压力测试接头总成	Connector	1	
86	WG9000361201	直角接头体NG8/NW6	Angle connector	1	
88	WG9000361202	直角接头体NG12/NW6	Angle connector	2	
90	WG9000361203	直角接头体NG12/NW12	Connector	1	
92	WG9000361204	直角接头体NG12/NW9	Angle connector	12	
94	WG9000361306	T型三通接头体NW9/NG12/	"T" Connector	2	
96	WG9000361110	直通接头体NG12/NW12	Connector	1	

8.19 HW6X4底盘制动装置（09版长轴距）/Chassis Brake Device

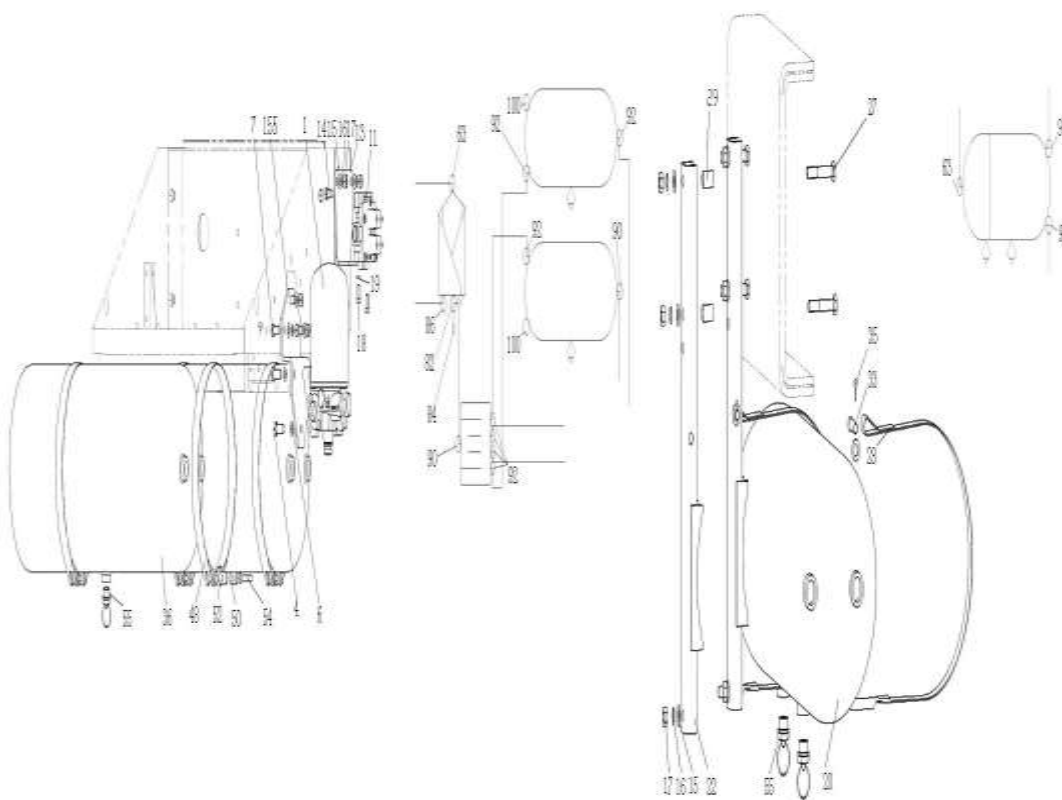

8.19 HW6X4底盘制动装置（09版长轴距）/Chassis Brake Device

序号 No.	零部件图号 Part No.	名称	Part Name	数量 Qty	备注 Remark
98	WG9000361106	直通接头体NG8/NW6	Connector	2	
100	WG9000361012	堵塞NG12-M22X1.5	Connector	2	
102	WG9000361323	L型三通接头体NW6/NW9/N	"L" Connector	1	
104	AZ9003179031	穿线护套	Protection sleeve	150mm	
105	190003179046	穿线护套	Protection sleeve	150mm	
106	190003179046	穿线护套	Protection sleeve	150mm	
107	WG17017361000	螺旋形护管	Protect pipe	2	

109	WG17017361000	螺旋形护管	Protect pipe	2	
111	WG9123360300	波纹护套 (φ30 黑色)	Protection sleeve	200mm	
113	WG9100360134	隔环	Spacer	10	
114	199100360134	隔环	Spacer	1	
115	WG9100360135	隔环	Spacer	10	
116	199100360135	隔环	Spacer	1	
118	190003171392	塑料紧固带	Fastener	25	
119	190003179030	护垫	Plate	39cm	
120	190003179030	护垫	Plate	39cm	
121	199012360441	角形支架	Bracket	1	
122	Q150B1035	六角头螺栓	Screw	1	
123	Q40110	平垫圈	Washer	1	
124	Q40310	弹簧垫圈	Spring washer	1	

8.19 HW6X4底盘制动装置 (09版长轴距) /Chassis Brake Device

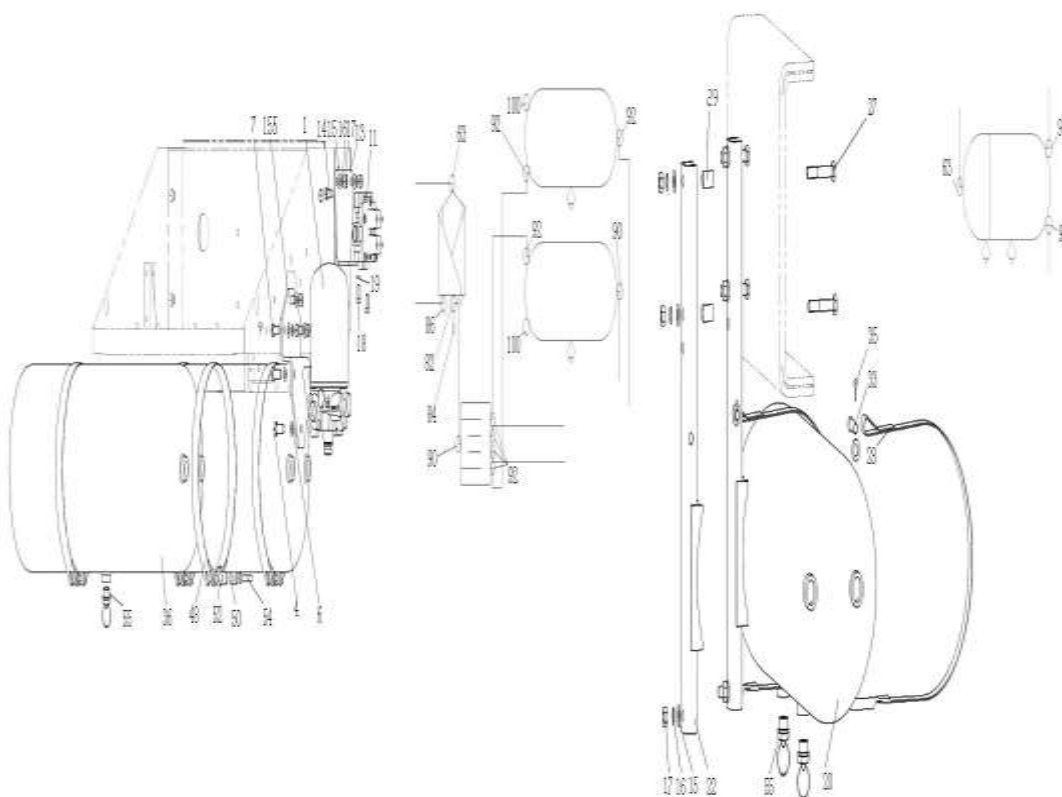

8.19 HW6X4底盘制动装置 (09版长轴距) /Chassis Brake Device

序号	零部件图号	名称	Part Name	数量	备注
No.	Part No.			Qty	Remark
125	Q340B10	六角螺母	Nut	1	
128	Q150B0620	六角头螺栓	Screw	1	
129	Q40106	平垫圈	Washer	1	
130	Q40306	弹簧垫圈	Spring washer	1	
131	Q340B06	I型六角螺母	Nut	1	

133	Q150B1225	螺栓	Screw	1	
134	Q40112	平垫圈	Washer	1	
135	Q40312	弹簧垫圈	Spring washer	1	
136	Q340B12	I型六角头螺母	Nut	1	
137	1880 360083	支承板	Plate	1	
138	Q150B1035	六角头螺栓	Screw	1	
139	Q40310	弹簧垫圈	Spring washer	1	
140	Q340B10	六角螺母	Nut	1	
141	Q40110	平垫圈	Washer	1	
143	WG9731360002	储气筒支架总成	Support ass.	2	
145	WG9100360104	储气筒支座总成	Support ass.	1	
153	WG9100360165	角形支架	Bracket	1	
155	WG9719360014	空气干燥器支架	Bracket	1	
157	WG9003170002	聚酰胺管 (Φ16*2)	Plastic pipe	3m	
159	WG9003171390	塑料紧固带B5*180	Fastener	30	

8.19 HW6X4底盘制动装置 (09版长轴距) /Chassis Brake Device

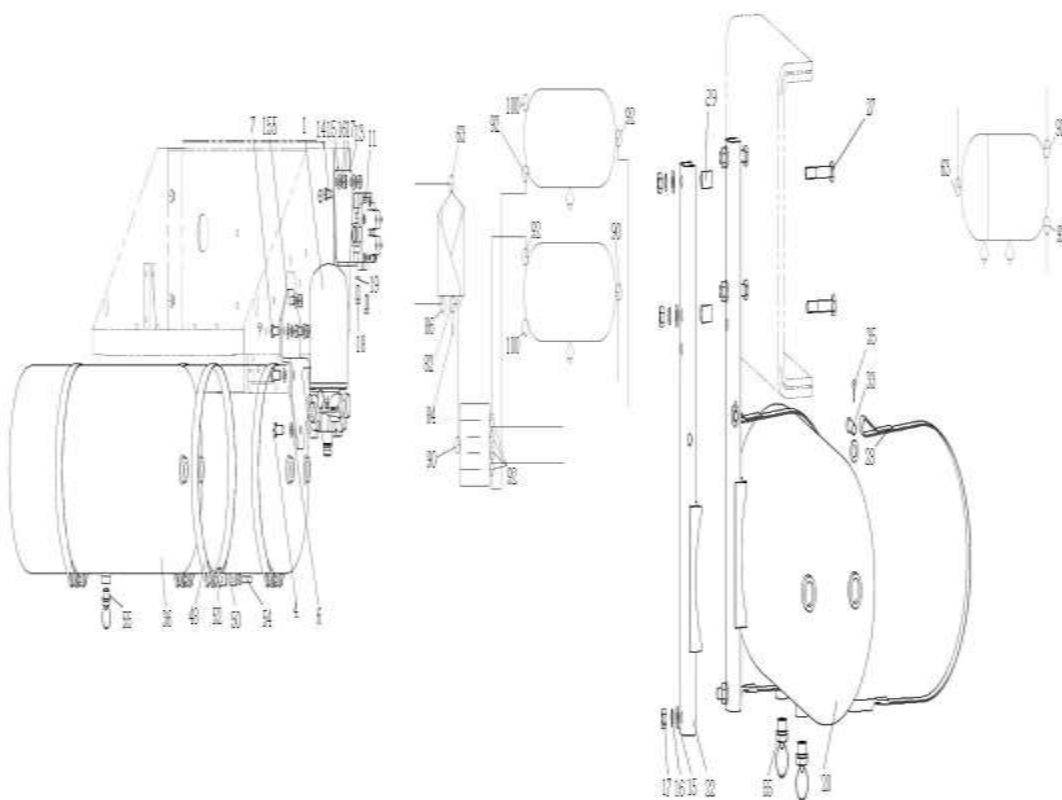

8.19 HW6X4底盘制动装置 (09版长轴距) /Chassis Brake Device

序号	零部件图号	名称	Part Name	数量	备注
No.	Part No.			Qty	Remark
161	WG85 770036	紧固夹子	Clip	1	
163	WG1000060211	橡胶软管 (Φ15/Φ21)	Hose	1	
165	WG9725270012	电磁阀支架	Bracket	1	

